



# QUAD

## SERVICE MANUAL

### MODEL QUAD ESL 2905

ESL 2905

#### ★ TABLE OF CONTENTS

---

SPECIFICATION-----	2
ASSEMBLY SKETCH-----	3
SCHEMATIC DIAGRAM-----	4
ASSEMBLY PART LIST-----	5
ELECTRONICS PARTS LIST-----	6

---

★ SPECIFICATION

**ESL 2905**

Maximum output:	2N/m <sup>2</sup> at 2m on axis
Sensitivity	1.5 mbar per volt referred to 1m
Impedance	8 ohms nominal
Impedance Variation	4-20 ohms
Maximum Input:	Continuous input voltage:10V Programme peak for undistorted output:40V Permitted peak input:55V
Frequency Response:	32Hz-21KHz (-6dB) 28Hz-21KHz (useable)
Directivity Index:	See Polar Diagrams
Distortion: (100dB at 1 metre)	Above 1000Hz 0.15% Above 100Hz 0.5% Above 50Hz 1.0%
AC Input:	220-240V or 110-120V
Power fuse	63 mA anti-surge, 200-240V 100mA anti-surge, 100-120V
Power consumption	6W
Dimensions: (H*W*D)	1430mm*695mm*385mm
Weight:	Net 41.6kg

# ★ ASSEMBLY SKETCH

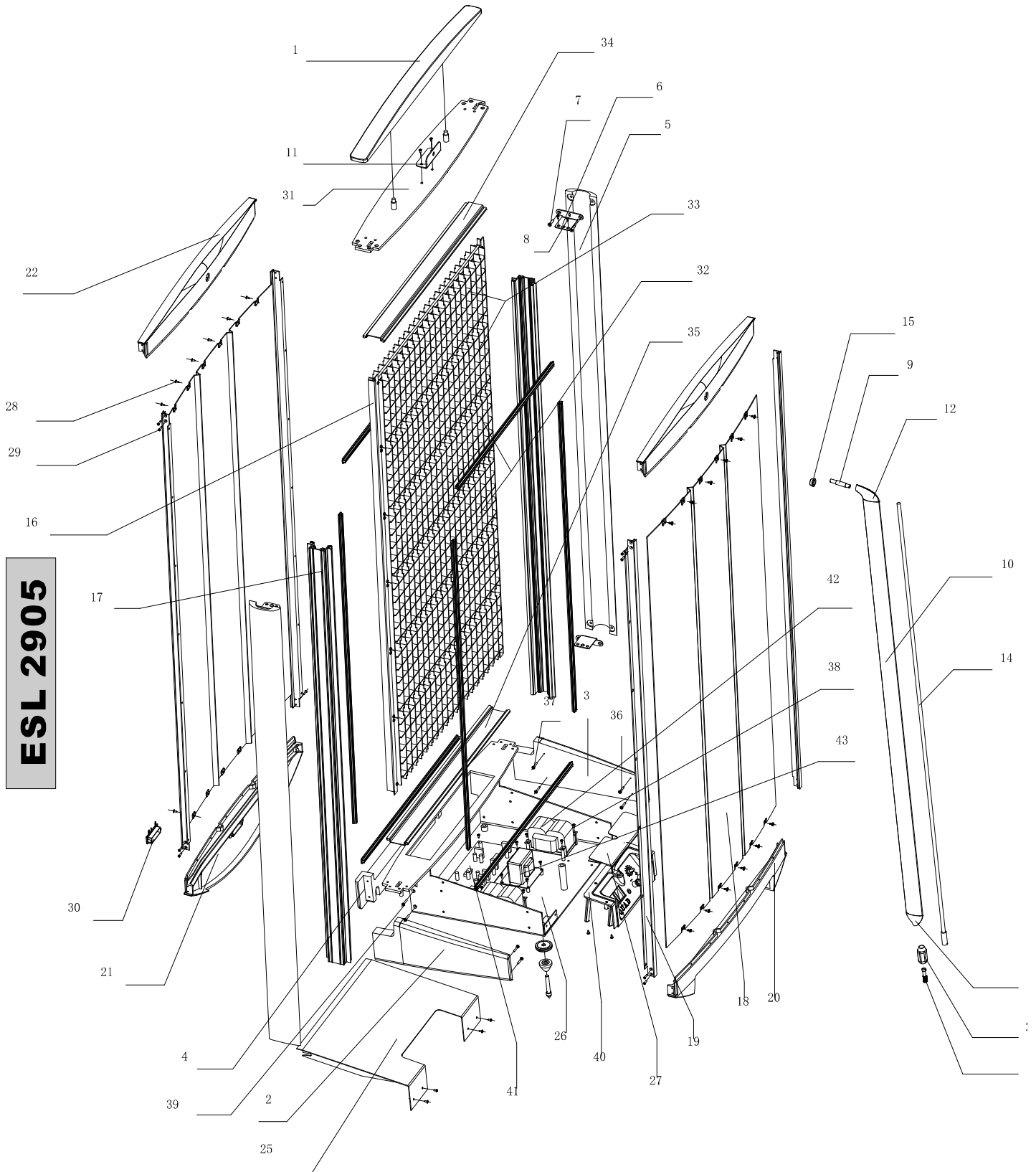

# ★ SCHEMATIC DIAGRAM

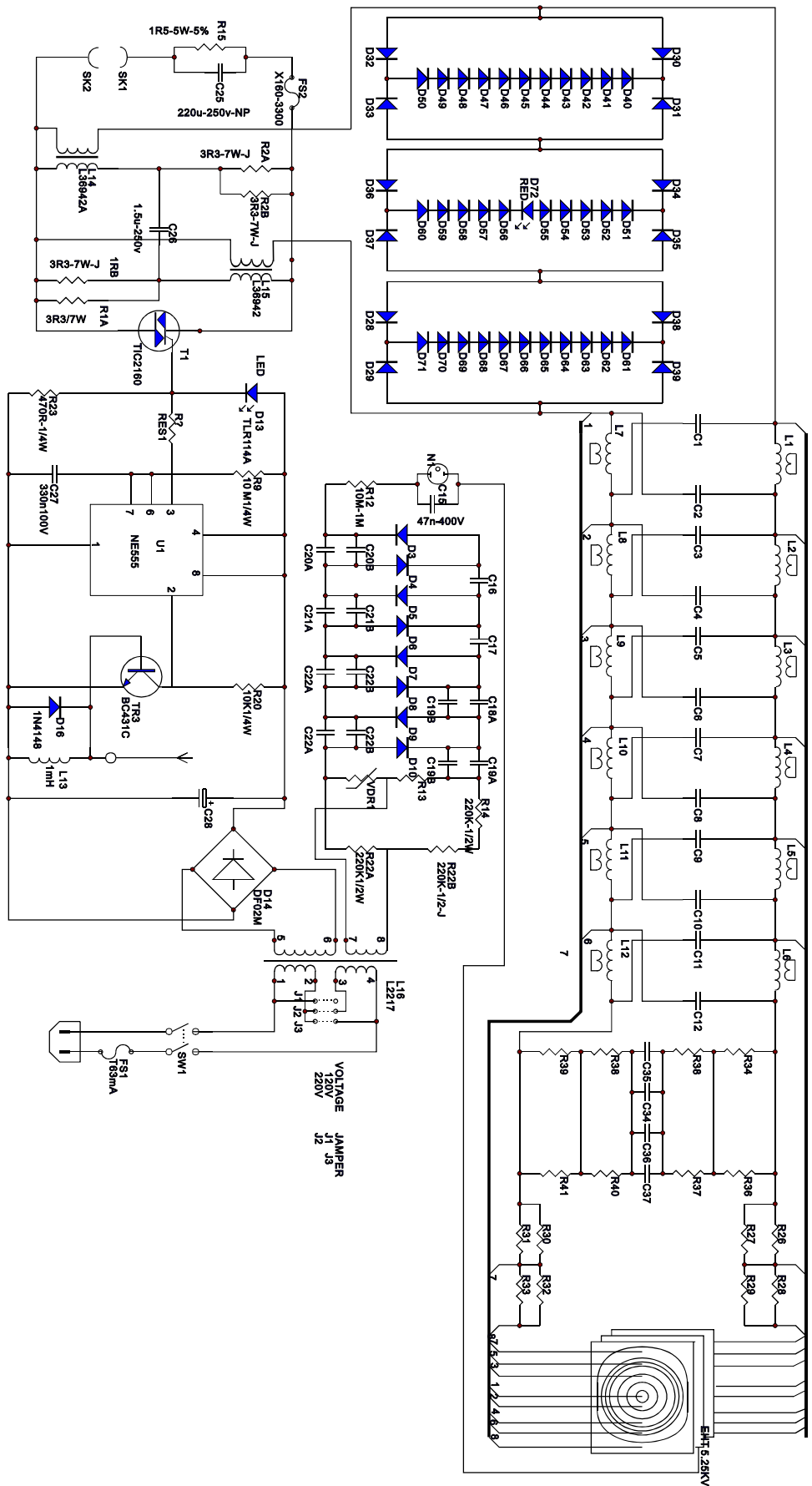

**ESL 2905**



# ASSEMBLY PARTS LIST

**ESL 2905**

R/N	P/N	PART NAME	DESCRIPTION	QUA
1	317-1277000002	TOP TRIM		1
2	308-1397000003	PLINTH LH TRIM		1
3	308-1397000004	PLINTH RH TRIM		1
4	308-1397000005	PLINTH FRONT TRIM		1
5	332-1121278004	SIDE TRIM		2
6	325-1397000000	SIDE TRIM BRACKET		4
7	534-5001080101	SCREWS	MS*8 BZn	8
8	537-5001100801A	SCREWS	MP(+)*5*10 BZn	6
9	575-0008050100	SCREWS		1
10	332-1278000000	AL STRUT		1
11	305-1397000000	TOP BRACE BRACKET		1
12	353-1278000000	STRUT TOP ARM		1
13	353-1277000000	STRUT BOTTOM COWLING		1
14	575-2012127520	STRUT THROUGH BOLT		1
15	360-1900911075	STUD HOLE TRIM		1
16	318-1278000000	MODULE VERTICAL RAIL		2
17	332-1111207004	VERTICAL		2
18	310-1397000002	GRILLE PERF		2
19	332-1001270003	GRILLE VERTICAL		4
20	203-1397000001	GRILLE MOTTOM REAR MOULDING		1
21	203-1397000002	GRILLE BOTTOM FRONT MOULDING		1
22	202-1397000002	GRILLE TOP MOULDING		2
23	328-1277000000	STRUT NUT		1
24	575-2008037100	STRUT BALL JOINT		1
25	302-1277000000	PLINTH COVER		1
26	303-1277000000	BOTTOM CHASSIS		1
27	202-1397000001	TERMINAL DOOR		1
28	553-3002086561A	SCREWS	3*8TA H BZn	38
29	554-3001120081	SCREWS	M3*12	16
30	217-1397000001	LOGO		1
31	302-1277000001	TOP BRACE		1
32	604-1193010010	MIDDLE SPEAKER		2
33	604-1193010011	UP AND DOWN SPEAKER		4
34	725-1155610301	HORIZONTAL RAIL		1
35	725-1156510301	HORIZONTAL RAIL		1
36	556-4001148061A	SCREWS	4. 0*14PA H	4
37	557-4001208061A	SCREWS	4. 0*20 PA H	4
38	537-3001080801A	SCREWS	MP(+)*3*8 BZN	16
39	554-4001208061A	SCREWS	4. 0*20 KAH	4
40	241-1397000000	TERMINAL PANEL		1
41	088-1183020030	MAIN BOARD		1
42	022-3000602045	TRANSFORMER		2
43	022-1016102037	TRANSFORMER		1



# ELECTRONICS PARTS LIST

**ESL 2905**

R/N	P/N	PART NAME	DESCRIPTION	QUA
1	020-5014111000Q	POTENTIOMETERS	R2411SNAW1 B502	1
2	022-1016102037	TRANSFORMER	BMK2184R1	1
3	022-3000602045	TRANSFORMER	T2G01001A	2
4	031-2200530121	SAFETY TUBE	50T0063H	1
5	041-2141000000	POWER SWITCH	C1350VB	1
6	044-0900000000	POWER SOCKET	R-3014GW (2PIN)	1
7	046-9900000003	TERMINAL POST		2
8	055-3902650533	FLAT LINE		1
9	060-0220200000A	WIRE	RED 1015#22 L=200mm	1
10	060-0220270000A	WIRE	RED 1015#22 L=270mm	1
11	060-0220380000A	WIRE	RED 1015#22 L=380mm	3
12	060-1000000601	WIRE		11.8
13	060-1000001301	LEAD		2
14	060-1000011301	LEAD		0.3
15	060-2220320100	LEAD	ORG 1015#22 L=320MM	1
16	060-3260000011	WIRE	UL1007AWG26# RED	1
17	060-3260000411	WIRE	UL1007AWG26# BLACK	0.5
18	060-4220121200	WIRE	WHT/BLK 1015#22 L=120MM	1
19	060-8240100400A	WIRE		2
20	060-9240140400A	WIRE		2
21	062-5330000100	POWER CORD		1
22	071-1100000000	CABLE TIES	100MM YJ-100	2
23	071-2480000000Q	CABLE TIES	YJ-330	2
24	085-0151500100	TUBE	15MM*150MM BLACK	1
25	085-0600800300	PVC TUBE	6MM*80MM YELLOW	3
26	085-0601000300	PVC TUBE	6MM*100MM YELLOW	1
27	085-0601300300	PVC TUBE	6MM*130MM YELLOW	1
	088-1074012430	COIL BOARD		2
1	008-3301100006	CAPACITOR	DHR15 ZM 331M 10K	4
2	053-1074011124	PCB BOARD	19*9.7CM FR-4 1.6MM	2
3	092-3004090500	RESISTOR	300K-100PPM-J	8
4	092-7204090500	RESISTOR	720K-100PPM-J	8
5	094-0100000000	COIL	163C01A	12
6	223-0532220301	PLASTIC POST	3-3	32
7	570-1025040051	RIVET		2
	088-1074012530	CAPACITOR BOARD		2
1	008-1009600006	CAPACITOR	DHR9 SL 10F AC6K	2
2	008-2209600006	CAPACITOR	DHR12 SL 22K AC6K	10
3	053-1074011125	PCB BOARD	8.4*4.7CM FR-4 1.6MM	2
4	086-1000000000	TERMINAL	PAM7072F TAG	14
	088-1183020030	MAIN BOARD	ESL989	1
1	001-0150510050	RESISTOR	SQP1.5 OHM 5W J	1
2	001-0330520050	RESISTOR	SQM3.3 OHM 7W J	4
3	001-1003105050	RESISTOR	10K 1/4W J	1

★ ELECTRONICS PARTS LIST

ESL 2905

4	001-1004205010	RESISTOR	100K 1/4W F	1
5	001-1006105050	RESISTOR	10M 1/4W J	1
6	001-1006107050	RESISTOR	10M OHM 1W K	1
7	001-1804107050	RESISTOR	180K OHM 1W J	1
8	001-2204106050	RESISTOR	220K OHM 1/2W J	2
9	001-3301105050	RESISTOR	330 OHM 1/4W J	1
10	001-4701105050	RESISTOR	470 OHM 1/4W J	1
11	004-4404000000	RESISTOR	S10V-S10K460	1
12	006-1024101633	CAPACITOR	SM1000U 16V M	1
13	006-2210183061	CAPACITOR	B06A 220uF 50V J 18*42	1
14	008-1003200016	CAPACITOR	103M 2KV	14
15	013-1550411004	CAPACITOR	B32562-J3155-K	1
16	013-3340311004	CAPACITOR	0.33u 100V (R60)	1
17	013-4730511004	CAPACITOR	MKT R60 47n 400V J	1
18	017-0660000001	IC	NE555P	1
19	018-1400237115	AUDION	BC237C TO-92	1
20	019-0511112000	LED	333HD/S636	2
21	026-1024102101	INDUCTANCE	CECL-812201 CECL-1R0K	1
22	053-1074011100	PCB BOARD	21.5*11.6CM FR-4 1.6MM	1
23	060-0220200000A	WIRE	RED 1015#22 L=200mm	1
24	060-0220380000A	WIRE	RED 1015#22 L=380mm	1
25	060-2260260900	WIRE	BLK/RED 1007#26 L=260MM	1
26	060-9240180400A	WIRE	#24L=180	1
27	067-1104148000	DIODE	IN4148	1
28	067-2200030000	DIODE	GP02-30	20
29	067-3300220000	DIODE	BZT03C-220	32
30	079-2501000000	PRESERVER	RXE250/60V	1
31	306-1074010001	RADIATOR		1
32	517-3000000800A	WASHER	M3 BZn	1
33	537-3001080801A	SCREWS	MP (+) 3*8 BZn D	1
34	570-1025040051	RIVET		16
	088-1277000800	LAMP BOARD		1
1	001-2002205010	RESISTOR	2K 1/4W F	1
2	019-0000017020Q	LED	LL-S170WC-W2-1B	10
3	053-1277000800	PCB BOARD	30*70MM	1